

Model 7516

Specifications

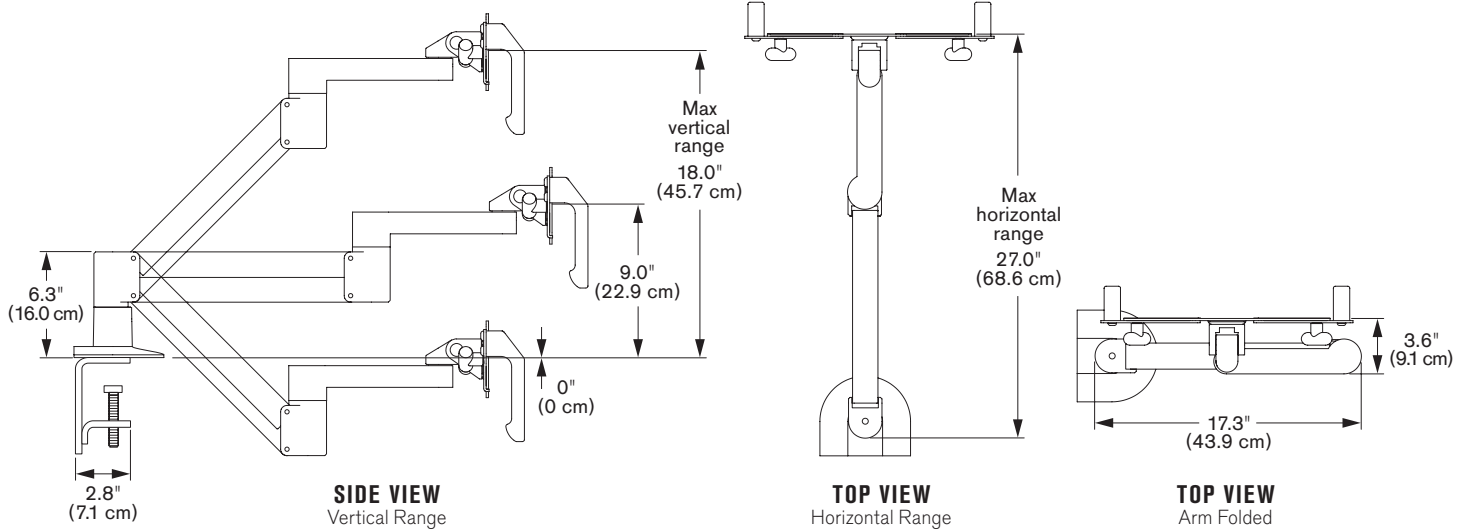

CAPABILITIES

Vertical range	+/- 9" (22.9 cm) from horizontal
Horizontal range	27" (68.6 cm)
Rotation	360 degrees at three joints
Monitor tilt	200 degrees
Monitor pivot	Landscape to portrait
Monitor compatibility	VESA® 75mm and 100mm
Cable management	Cables are concealed in arm
Mounting options	FLEXmount™, wall, pole, thru-desk
Monitor weight/model number	0.5 - 16.5 lbs (0.2 - 7.5 kg) / 7516-800 2.5 - 22.5 lbs (1.1 - 10.2 kg) / 7500-1000 13.5 - 37.5 lbs (6.1 - 17.0 kg) / 7500-1500

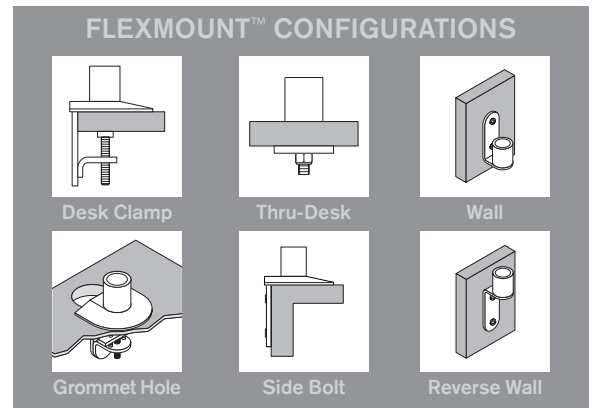

OPTIONAL ACCESSORIES

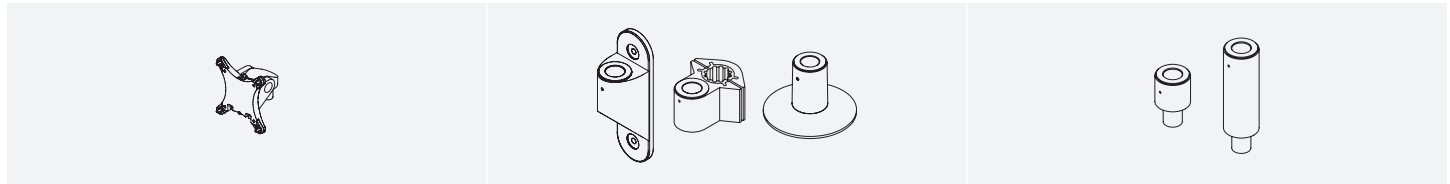

QUICK RELEASE ADAPTERS
Allows for quick attach and release of monitor (8336-QR).

MOUNTS
Wall (8325), pole (8210) and thru-desk (8312).

EXTENDER TUBES
Raise the height of your arm. 2" (8171-75-2) and 6" (8171-75-6) extensions available.

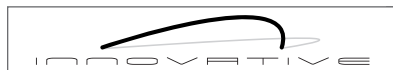

Phone: 800.524.2744 | Fax: 610.253.9521 | E-mail: sales@LCDarms.com | Web: www.LCDarms.com

This product is protected by one or more of the following U.S. Patent Nos. and other United States and foreign patents applied for: 119,345, 119,346, 1,324,842, 2,470,525, 6,076,785, 6,273,383, 6,409,134, 6,478,274, 6,499,704, 6,505,988, 6,609,691, 6,191,606, 6,719,253, 6,726,167, 6,736,364, 6,783,105, 6,854,698, 6,915,994, 6,935,883, 6,955,328, 6,983,917, 6,986,489, 7,014,157, 7,017,874, 7,048,242, 7,059,574, 7,063,296, 7,066,433, 7,066,435, 7,389,965, D435,852, D491,952, D492,893, D570,853, D575,293.